

(en) Electric current! Danger to life!
Only skilled or instructed persons may carry out the following operations.

(de) Lebensgefahr durch elektrischen Strom!
Nur Elektrofachkräfte und elektrotechnisch unterwiesene Personen dürfen die im Folgenden beschriebenen Arbeiten ausführen.

(fr) Tension électrique dangereuse !
Seules les personnes qualifiées et averties doivent exécuter les travaux ci-après.

(es) ¡Corriente eléctrica! ¡Peligro de muerte!
El trabajo a continuación descrito debe ser realizado por personas cualificadas y advertidas.

(it) Tensione elettrica: Pericolo di morte!
Solo persone abilitate e qualificate possono eseguire le operazioni di seguito riportate.

(zh) 触电危险!
只允许专业人员和受过专业训练的人员进行下列工作。

(ru) Электрический ток! Опасно для жизни!
Только специалисты или проинструктированные лица могут выполнять следующие операции.

(nl) Levensgevaar door elektrische stroom!
Uitsluitend deskundigen in elektriciteit en elektrotechnisch geïnstrueerde personen is het toegestaan, de navolgend beschreven werkzaamheden uit te voeren.

(da) Livsfare på grund af elektrisk strøm!
Kun uddannede el-installatører og personer der er instruerede i elektrotekniske arbejdsopgaver, må udføre de nedenfor anførte arbejder.

(el) Προσοχή, κίνδυνος ηλεκτροπληξίας!
Οι εργασίες που αναφέρονται στη συνέχεια θα πρέπει να εκτελούνται μόνο από ηλεκτρολόγους και ηλεκτροτεχνίτες.

(pt) Perigo de vida devido a corrente eléctrica!
Apenas electricistas e pessoas com formação electotécnica podem executar os trabalhos que a seguir se descrevem.

(sv) Livsfara genom elektrisk ström!
Endast utbildade elektriker och personer som undervisats i elektroteknik får utföra de arbeten som beskrivs nedan.

(fi) Hengenvaarallinen jännite!
Vain pätevät sähköasentajat ja opastusta saaneet henkilöt saavat suorittaa seuraavat työt.

(cs) Nebezpečí úrazu elektrickým proudem!
Níže uvedené práce smějí provádět pouze osoby s elektrotechnickým vzděláním.

(et) Eluhtlik! Elektrilöögiolt!
Järgnevalt kirjeldatud töid tohib teostada ainult elektriala spetsialist või elektrotehnilise instrueerimise läbinud personal.

(hu) Életveszély az elektromos áram révén!
Csak elektromos szakemberek és elektrotechnikában képzett személyek végezhetik el a következőkben leírt munkákat.

(lv) Elektriskā strāva apdraud dzīvību!
Tālāk aprakstītos darbus drīkst veikt tikai elektrospeciālisti un darbam ar elektrotehniskām iekārtām instruētās personas!

(it) Pavojuv gyvybei dėl elektros srovės!
Tik elektrikai ir elektrotechnikos specialistai gali atlikti žemiau aprašytus darbus.

(pl) Porażenie prądem elektrycznym stanowi zagrożenie dla życia!
Opisane poniżej prace mogą przeprowadzać tylko wykwalifikowani elektrycy oraz osoby odpowiednio poinstruowane w zakresie elektrotechniki.

(sl) Življenjska nevarnost zaradi električnega toka!
Spodaj opisana dela smejo izvajati samo elektrostrokovnjaki in elektrotehnično poučene osebe.

(sk) Nebezpečnosť ohrozenia života elektrickým prúdom!
Práce, ktoré sú nižšie opísané, smú vykonávať iba elektroodborníci a osoby s elektrotechnickým vzdelaním.

(bg) Опасност за живота от електрически ток!
Операциите, описани в следващите раздели, могат да се извършват само от специалисти-електротехници и инструктиран електротехнически персонал.

(ro) Atenție! Pericol electric!
Toate lucrările descrise trebuie efectuate numai de personal de specialitate calificat și de persoane cu cunoștințe profunde în electrotehnică.

DXA-EXT-ENCOD

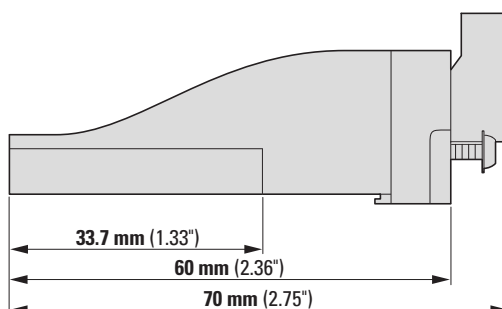
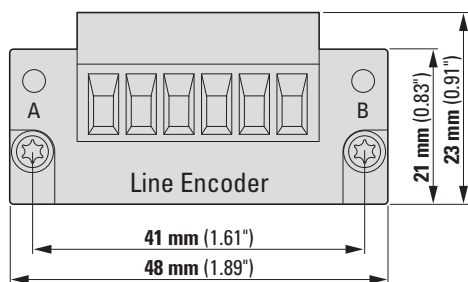
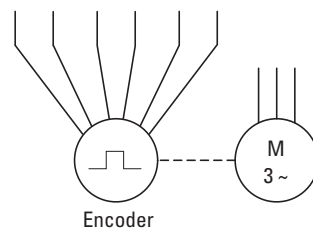
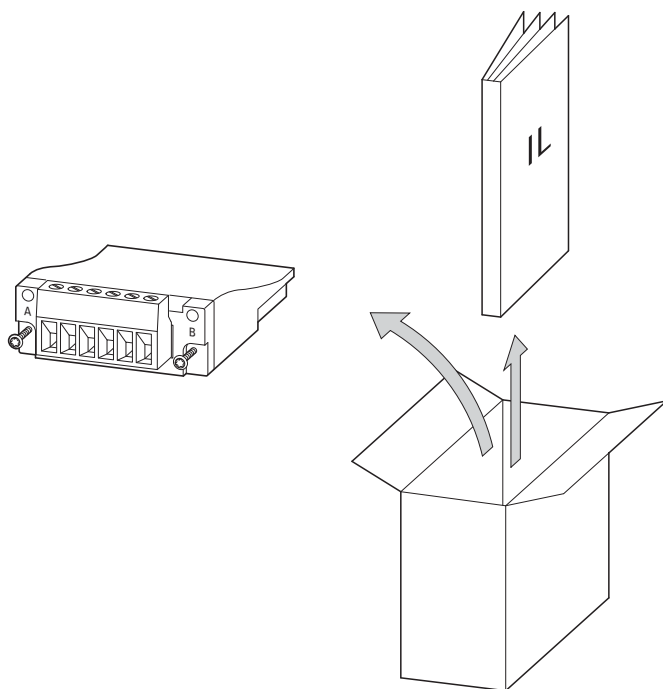

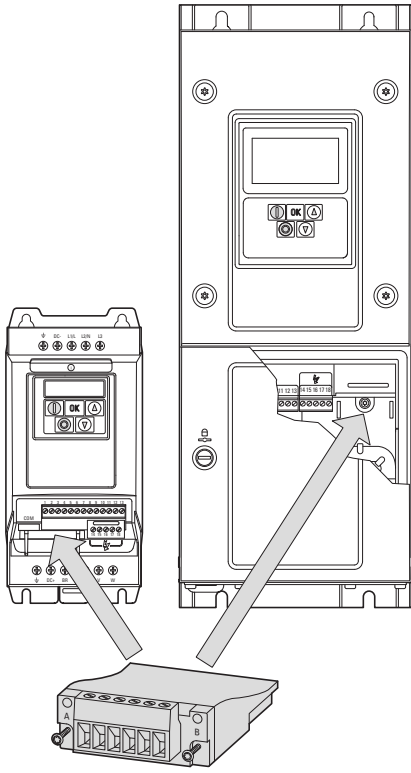

FS2, FS3

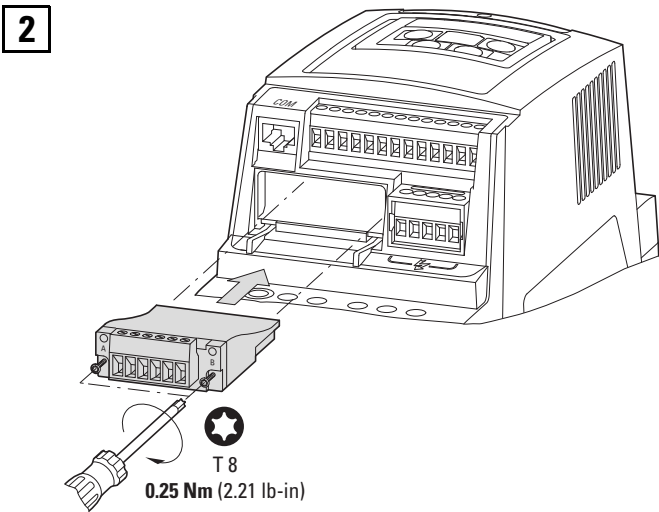
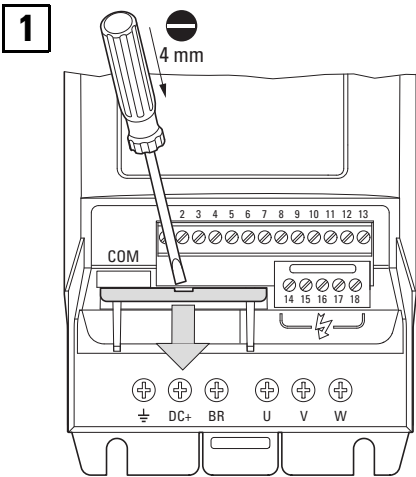



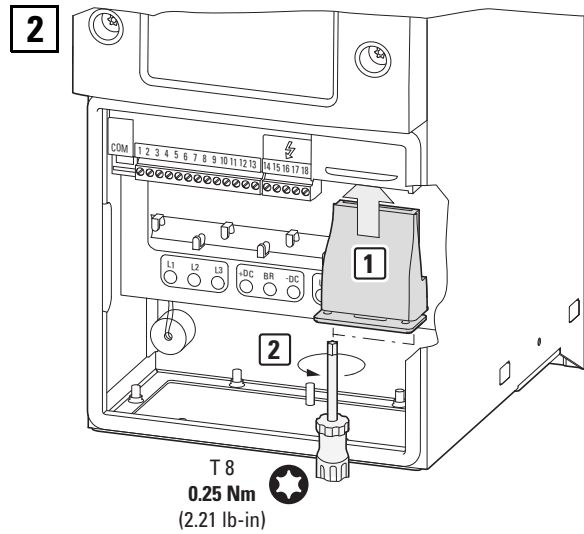
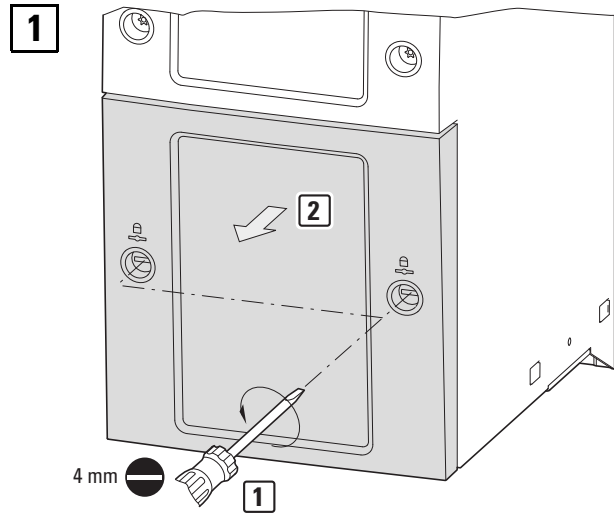

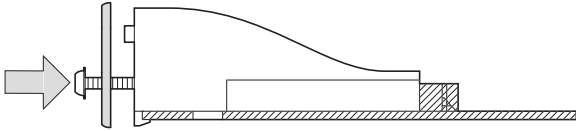
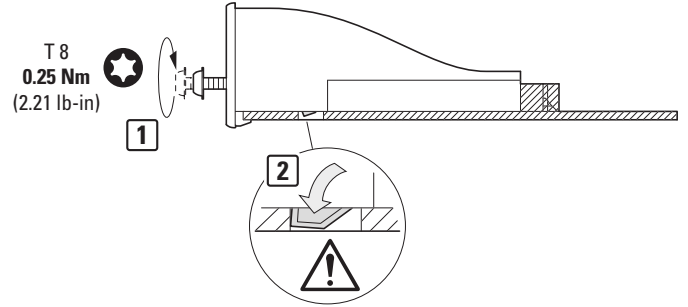

FS4...FS7



10/12 IL04012013Z

1**2**

						
mm ²	mm ²	AWG	mm	M3	Nm	lb-in
0.14 - 2.5	0.14 - 2.5	30 - 12	6		0.5	4.43
			in			0.4 x 2.5

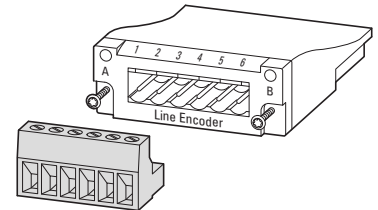

10/12 IL04012013Z

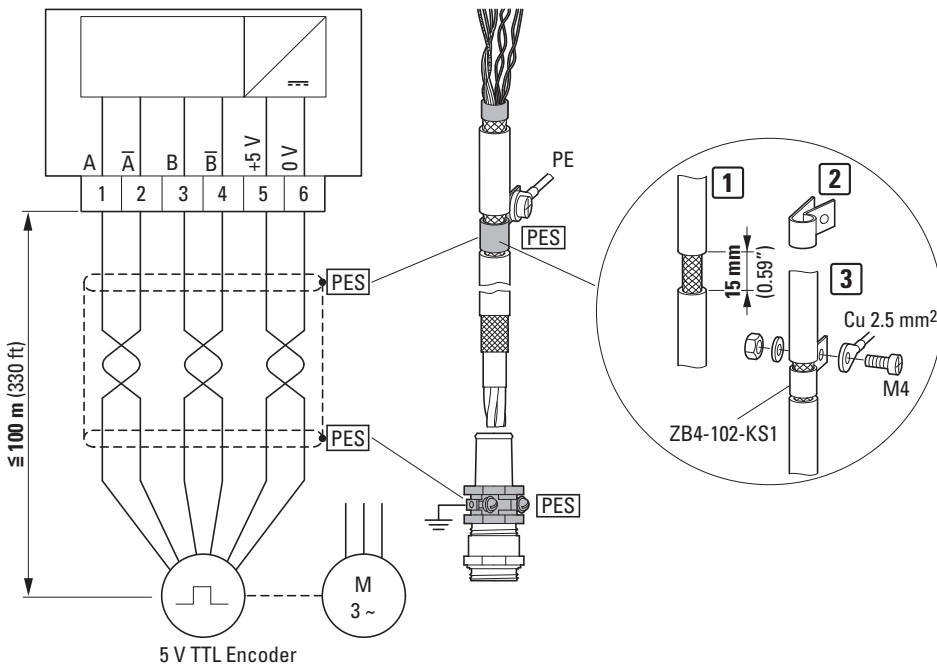

TTL (RS422)

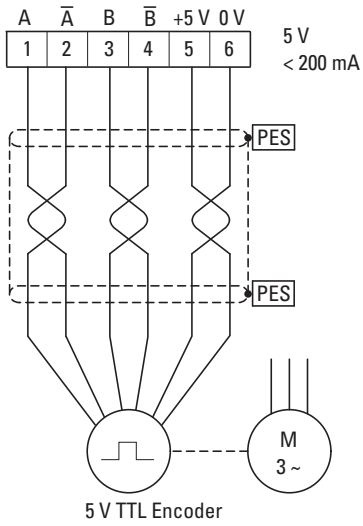

HTL

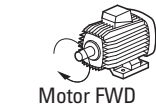
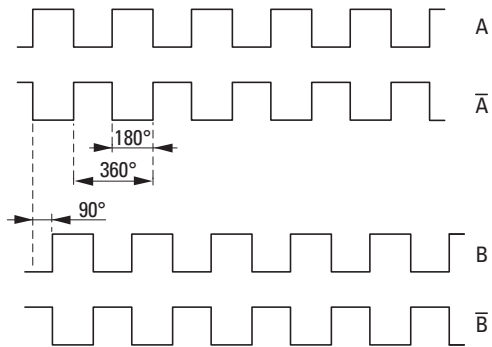
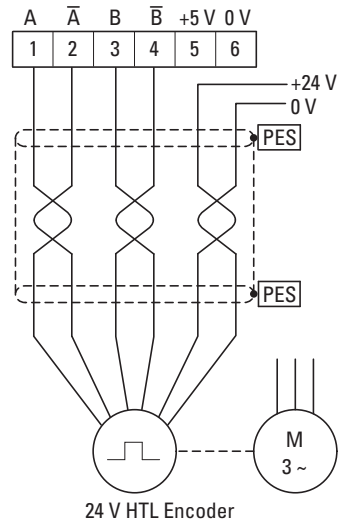

$\leq 500 \text{ kHz}$
 $\leq 300 \text{ V DC}$
 PPR: \square / \square / \square \Rightarrow P6-06

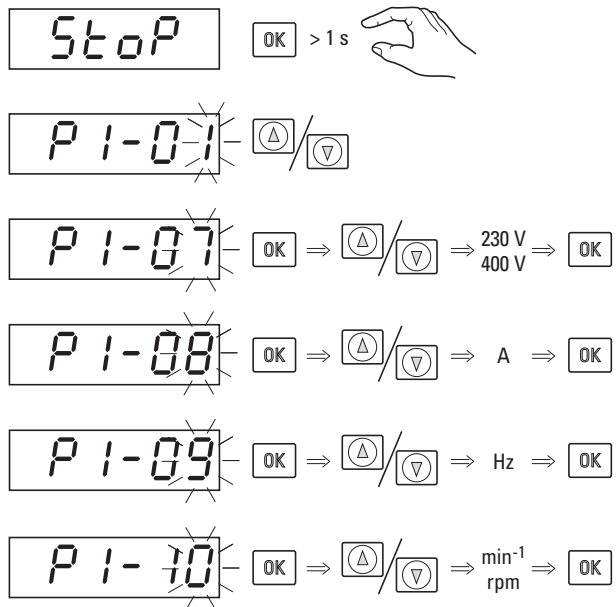
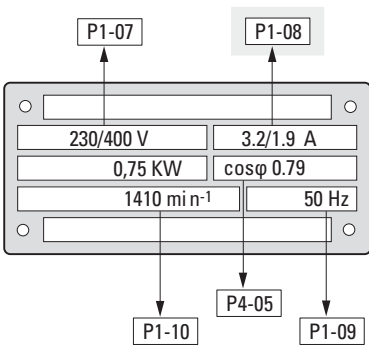

10/12 IL04012013Z

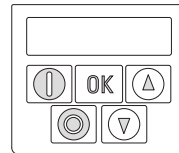
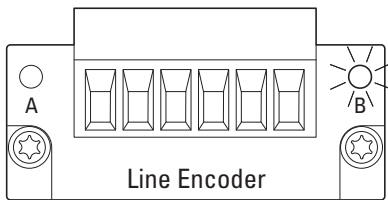
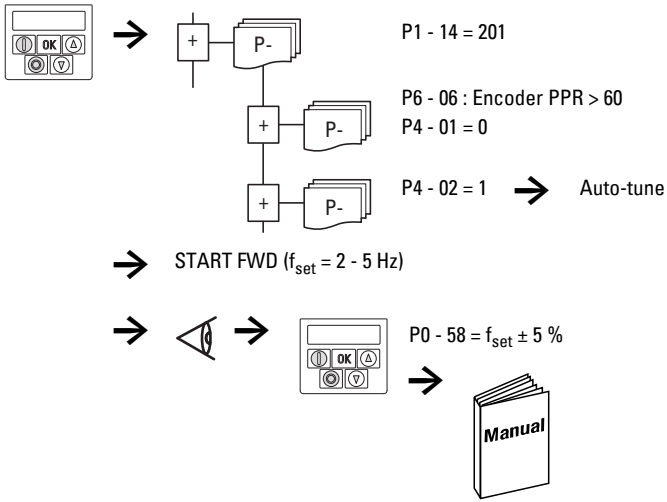

- ① E_{nc-01} Communication loss
- ② E_{nc-02}
 - Speed feedback (P6 - 07)
 - Encoder connection
- ③ E_{nc-03} Encoder PPR < 60
- ④ E_{nc-04} Fault Channel A
- ⑤ E_{nc-05} Fault Channel B
- E_{nc-06} Fault Channel A & B

10/12 IL04012013Z

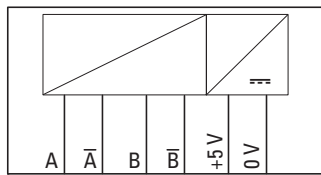

①

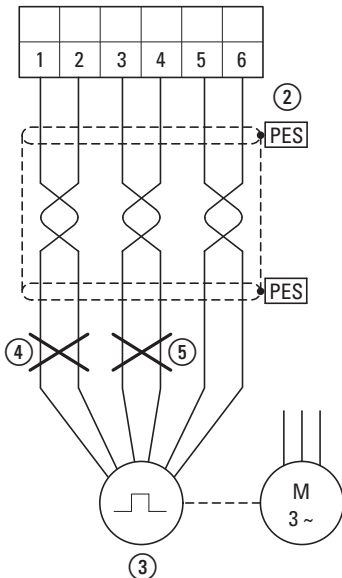

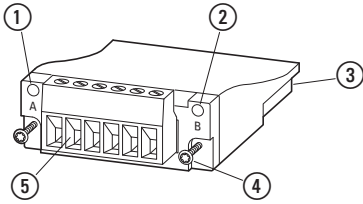

(en)

- ① LED A (green): Supply voltage
- ② LED B (red): Error message
- ③ 50-pole connector strip
- ④ Screws for securing frequency inverter DA1
- ⑤ 6-pole plug-in terminal

(de)

- ① LED A (grün): Versorgungsspannung
- ② LED B (rot): Fehlermeldung
- ③ 50-polige Steckleiste
- ④ Schrauben zur Befestigung am Frequenzumrichter DA1
- ⑤ 6-polige Steckklemme

(fr)

- ① LED A (vert) : tension d'alimentation
- ② LED B (rouge) : signalisation de défaut
- ③ Bornier 50 pôles
- ④ Vis pour fixation sur convertisseur de fréquence DA1
- ⑤ Bornier enfichable, 6 pôles

(es)

- ① LED A (verde): tensión de alimentación
- ② LED B (rojo): señalización de defectos
- ③ Regleta enchufable de 50 polos
- ④ Tornillos para la fijación en el convertidor de frecuencia DA1
- ⑤ Borne de enchufe de 6 polos

(it)

- ① LED A (verde): tensione di alimentazione
- ② LED B (rosso): segnalazione di guasto
- ③ Connettore strip 50 poli
- ④ Viti di fissaggio al convertitore di frequenza DA1
- ⑤ Morsetto ad innesto a 6 poli

(zh)

- ① LED A (绿色): 供电电压
- ② LED B (红色): 错误消息
- ③ 50 针插排
- ④ 用于固定变频器 DA1 的螺钉
- ⑤ 6 针插入式端子

(ru)

- ① Светодиод А (зеленый): питающее напряжение
- ② Светодиод В (красный): сообщение об ошибке
- ③ 50-контактная штекерная колодка
- ④ Винты для крепления на преобразователе частоты DA1
- ⑤ 6-полюсная вставная клемма

(nl)

- ① LED A (groen): voedingsspanning
- ② LED B (rood): storingsindicatie
- ③ 50-polige connector
- ④ Schroeven voor bevestiging o frequentie-omvormer DA1
- ⑤ 6-polige steekklem

(da)

- ① LED A (grøn): forsyningspænding
- ② LED B (rød): Fejlmelding
- ③ 50-polet stikliste
- ④ skruer til fastgørelse på frekvensomformer DA1
- ⑤ 6-polet stikklemme

(el)

- ① LED A (πράσινη): τάση τροφοδοσίας
- ② LED B (κόκκινη): μήνυμα σφάλματος
- ③ Λωδίδα συνδετήρα 50 πόλων
- ④ Βίδες για τη στερέωση στο μετατροπέα συχνότητας DA1
- ⑤ 6-πολικό βύσμα ακροδέκτη

(pt)

- ① LED A (verde): tensão de alimentação
- ② LED B (vermelho): mensagem de erros
- ③ Ligador de 50 pinos
- ④ Parafusos para fixação no conversor de frequência DA1
- ⑤ Terminal de encaixe de 6 polos

(sv)

- ① LED A (grön): försörjningsspänning
- ② LED B (röd): felmeddelande
- ③ 50-polig kopplingsplint
- ④ Skruvar för fastsättning på frekvensomriktare DA1
- ⑤ 6-polig insticksplint

(fi)

- ① LED A (vihreä): Syöttöjännite
- ② LED B (punainen): Virheviesti
- ③ 50-napainen kaapeliliitin
- ④ Ruuvit taajuusmuuttajan DA1 kiinnitykseen
- ⑤ 6-napainen pistokeliitin

(cs)

- ① LED A (zelený): napájecí napětí
- ② LED B (červený): chybová hlášení
- ③ 50pólová zástrčková lišta
- ④ Šrouby k upevnění na frekvenční měnič DA1
- ⑤ Zásuvná svorka, 6 pólů

(et)

- ① LED A (roheline): toitepinge
- ② LED B (punane): veateade
- ③ 50-poolusega pistikühendus
- ④ Kruvid sagedusmuunduri DA1 külge kinnitamiseks
- ⑤ 6-poolusega pistikklemm

(hu)

- ① LED A (zöld): tápfeszültség
- ② LED B (piros): hibaüzenet
- ③ 50 pólusú sorkapocs
- ④ Csavarok a DA1 frekvenciaváltóra való rögzítéshez
- ⑤ 6 pólusú sorkapocs

(lv)

- ① LED A (zaļa): barošanas spriegums
- ② LED B (sarkana): kļūmes paziņojums
- ③ 50 polu spraudkontaktu savienojumu panelis
- ④ Skrūves piestiprināšanai pie frekvences pārveidotāja DA1
- ⑤ 6- polu spraudspaiļe

(lt)

- ① LED A (žalias): maitinimo įtampa
- ② LED B (raudonas): gedimo pranešimas
- ③ 50 polių kištukinis skydelis
- ④ Varžtai, skirti tvirtinti prie dažnio keitiklio DA1
- ⑤ 6 polių kištukinis gnybtas

(pl)

- ① Wskaźnik LED A (zielony): napięcie zasilające
- ② Wskaźnik LED B (czerwony): komunikat o błędzie
- ③ Listwa wtykowa 50-biegunowa
- ④ Śruby do zamocowania na przetwornicy częstotliwości DA1
- ⑤ Złącze wtykowe 6-biegunowe

(sl)

- ① LED A (zelena): oskrbovalna napetost
- ② LED B (rdeča): sporočilo napake
- ③ 50-polna vtična letev
- ④ Vijaki za pritrditev na frekvenčni pretvornik DA1
- ⑤ šestpolna vtična sponka

(sk)

- ① LED A (zelená): Napájacie napätie
- ② LED B (červená): Chybové hlásenie
- ③ 50-pólová svorkovnica
- ④ skrutky pre upevnenie na menič frekvencie DA1
- ⑤ 6-pólová svorkovnica

(bg)

- ① Светодиод А (зелен): захранващо напрежение
- ② Светодиод В (червен): съобщение за грешка
- ③ 50-полюсен контактен разклонител
- ④ Винтове за фиксиране към честотния преобразувател DA1
- ⑤ 6-полюсен клеморед

(ro)

- ① LED A (verde): tensiune de alimentare
- ② LED B (roșu): mesaj de eroare
- ③ Regletă de conexiuni 50 poli
- ④ Șuruburi pentru fixarea la convertizorul de frecvență DA1
- ⑤ Regletă de conexiuni 6 poli